

LYSAGHT ROOFTRAK®

Roof walkway system (Not available in Victoria)

LYSAGHT ROOFTRAK® is a safe, stable, slip-resistant walkway system for incidental access to roof-mounted equipment and services. It is laid on top of steel roofing with brackets designed for application to various roof cladding profiles.

It must be installed parallel or 90 degrees to the ribs of the roofing sheets. It is simple to install, corrosion resistant, flexible in layout, and light for easy handling.

Anti-skid surface

The pattern of anti-skid teeth can provide excellent grip with various shoe sole materials in many hazardous conditions like oil, grease, water, soap and mud. The surface is self-draining and easily cleaned. The slots afford free passage of water and air.

Application

ROOFTRAK walkways may be used in

cyclonic and non-cyclonic areas. For use in cyclonic areas it must be installed in accordance with this publication, and the roof cladding must be fixed in accordance with our cyclonic area design manual for steel roofing and walling available from www.lysaght.com or contacting a BlueScope Lysaght representative.

Australian Standard 1657—1992 allows a maximum slope of 20 degrees along cleated or grated walkways. For ROOFTRAK installed at 90 degrees to the ribs, the side slope (pitch of roof) should not exceed five degrees (5°).

The roof supporting ROOFTRAK must be verified to have sufficient capacity to withstand all the additional loads. For ROOFTRAK 450 applications, approval from regulatory authorities must be obtained as it is narrower than the minimum provided for in AS 1657-1992.



Roofing & Walling Products



Structural Products



Rainwater Products



Fencing Products



House Framing Products



Customer Support



Home Improvements

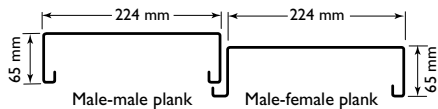

Configurations

ROOFTRAK is supplied in kits that include components and fixings.

The basic ROOFTRAK 'plank' is 224 mm wide. The ROOFTRAK 450 system uses two planks (total 450 mm wide); ROOFTRAK 675 uses three planks (total 675 mm wide).

Alternative Claddings

ROOFTRAK can be used with a range of claddings. When used with KLIP-LOK 700 High Strength and oriented in the same direction as the cladding, an additional stiffening plate must be included.

Material

The planks of ROOFTRAK are made from galvanised BlueScope Steel ZINCFORM® steel conforming to AS 1397—2001, grade G300, Z450 (300 MPa minimum yield stress, 450 g/m² minimum coating mass), with a base metal thickness of 1.2 mm (2.0 mm is subject to enquiry).

Lengths & tolerances

Stock lengths: 3018 mm and 6075 mm; +0 mm, -6 mm

Depth: +1 mm, -1 mm

Width: +0 mm, -2 mm

Adverse conditions

If this product is to be used in marine, severe industrial, or corrosive environments, get advice from our information line.

Installation

Before you start

In planning where your walkway will go, consider:

- Where the start and finish of the walkway will be;
- Whether the ROOFTRAK is laid either parallel to, or at 90 degrees to the roofing ribs, or both; and
- ROOFTRAK laid at 90 degrees to the roofing ribs should be directly over the purlins or battens supporting the roofing.
- Certain profiles (such as KL700HS) may require an additional stiffening plate. A Universal Support Plate is available for this situation.
- In some projects a larger gap may be required between the cladding and the ROOFTRAK. In these situations a packer or spacer can be installed that is installed between the Support Bracket and the cladding ribs.

Position support brackets

Position the first support bracket.

- If the ROOFTRAK is to be parallel to the roofing ribs: position the support bracket centrally across the ribs, ensuring that it is square to the roofing ribs (Figure 1).

If using KL700HS, ensure the stiffening plate is placed below the bracket. This plate should extend to the next rib. (Figure 3)

- If the ROOFTRAK is to be 90 degrees to the roofing ribs: position the support bracket directly over purlins or battens, and parallel with roofing ribs (Figure 2)

When a larger gap is required then thin packers or profiled spacers can be installed. Thin packers can be sandwiched between the Support

Bracket and the cladding ribs as described for stiffening plates. Deeper profiled spacers will need to be first fixed to the cladding ribs, (as described for the Support Brackets) The support brackets are then in turn fixed to the top of the profiled spacer.

For stability the profiled spacer should be rigid and a continuous length extending over the cladding ribs for the full length of the Support Bracket. The material used for the packer or spacer must be durable and also compatible.

Position the second and subsequent support brackets on a rib nominally 1500 mm from the previous support bracket (Figures 1 and 2). Use a string line and/or square to ensure a straight run.

Fix the support brackets with three Bulb-tite® rivets into the cladding ribs.

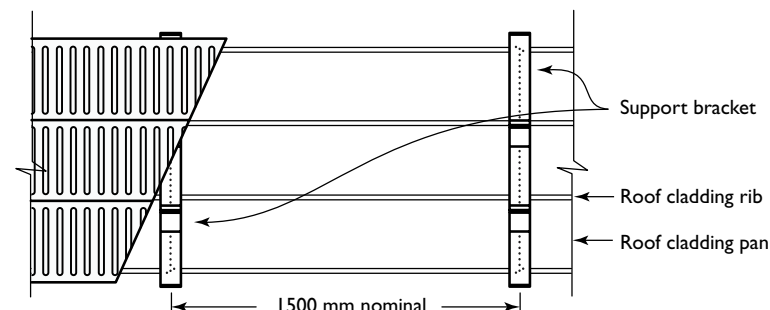

Figure 1
ROOFTRAK laid parallel to roofing ribs

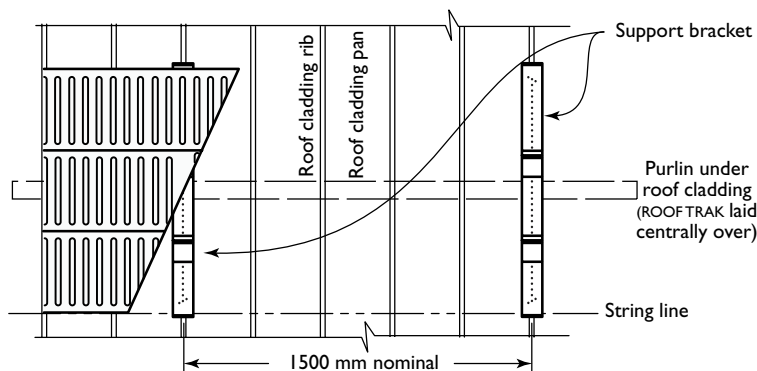

Figure 2
ROOFTRAK laid 90 degrees to roofing ribs

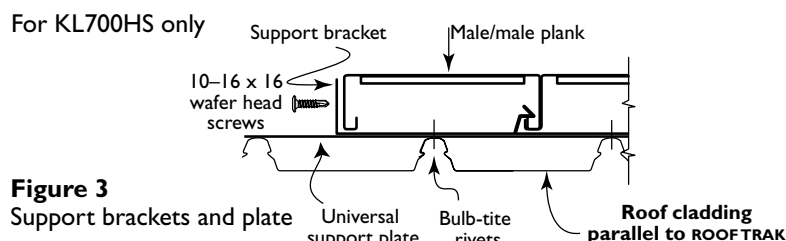
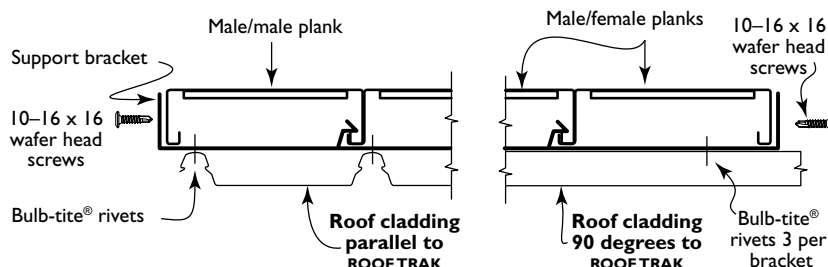

Figure 3
Support brackets and plate

Lay the planks

Lay the ROOFTRAK planks between the brackets and stand on the planks to engage them (there is one male/male plank that is positioned at the edge of the walkway (Figure 4). Fix the planks to the support brackets with four 10—16 x 16 wafer-head, self drilling screws per bracket (Figures 4 and 5).

Ends of planks

- If the ROOFTRAK is parallel with the roofing ribs, a single support bracket may be used to support the ends of two abutting rooftrak planks.
- If the ROOFTRAK is 90 degrees to the roofing ribs, a support bracket must be used on a roofing rib as close to the end of each plank to support the ends of two abutting ROOFTRAK planks.

An end plate is used at the open end of a ROOFTRAK plank that abuts nothing (Figure 6).

Tee or L intersections

- Fit end plates to the open ends of the planks that don't abut anything. If required, fix with 10—16 x 16 wafer-head screws.
- Fix support brackets to deck ribs at centres not greater than about 1500 mm.
- Fix planks in place and secure the intersection with an L-bracket(s) (Figure 6).

Cross intersections

- Continue one unbroken run of ROOFTRAK planks through the intersection (Figure 7).
- Fix support brackets on either side of the intersection to support the ends of the two broken runs of ROOFTRAK.
- Fix planks in place and fasten an L-bracket to each corner of the intersection, with two 10—16 x 16 wafer-head screws per bracket (Figure 7).

Important: Clean up swarf

Sweep all metallic swarf and other debris from roof areas and gutters at the end of each day and at the completion of the installation.

Failure to do so can lead to surface staining when the metal particles rust.

Component parts

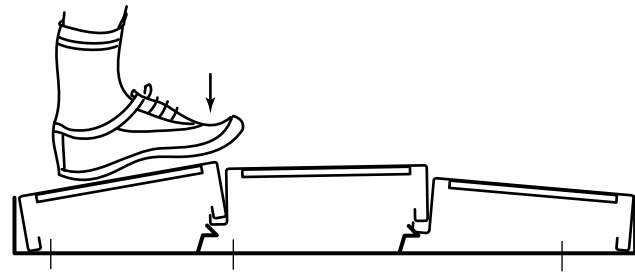

Figure 4
End section and laying

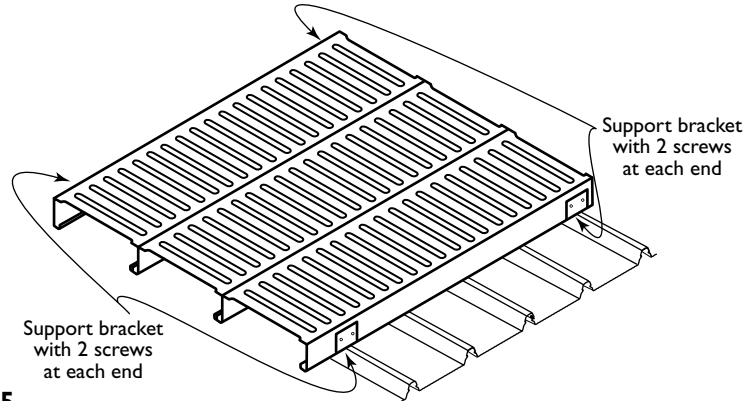

Figure 5
Fixing planks to support brackets

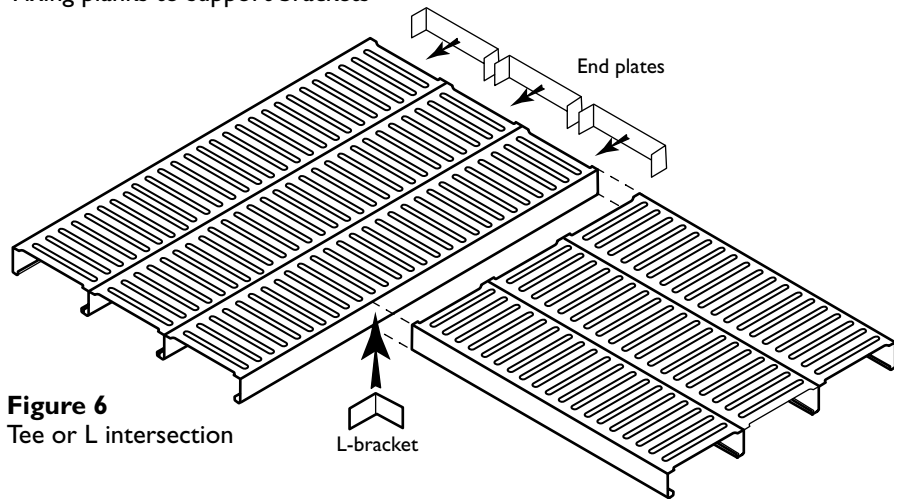

Figure 6
Tee or L intersection

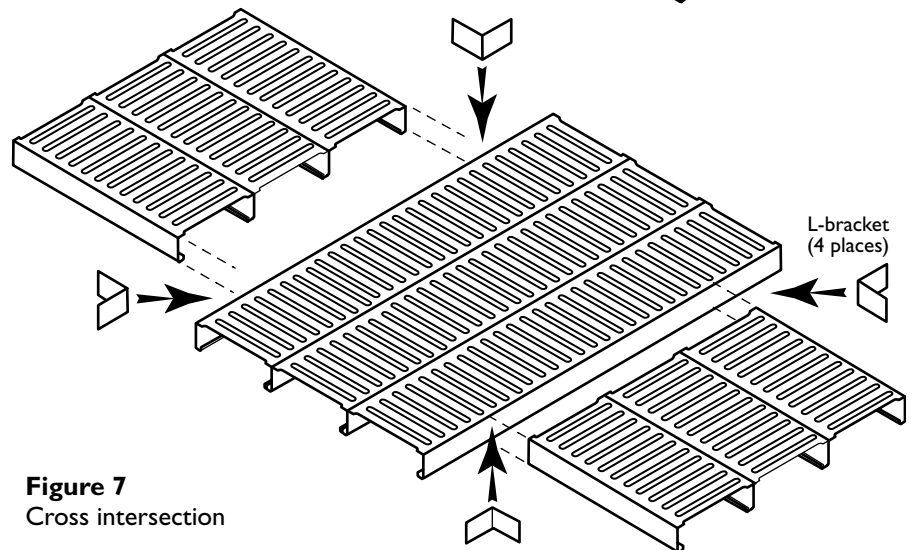
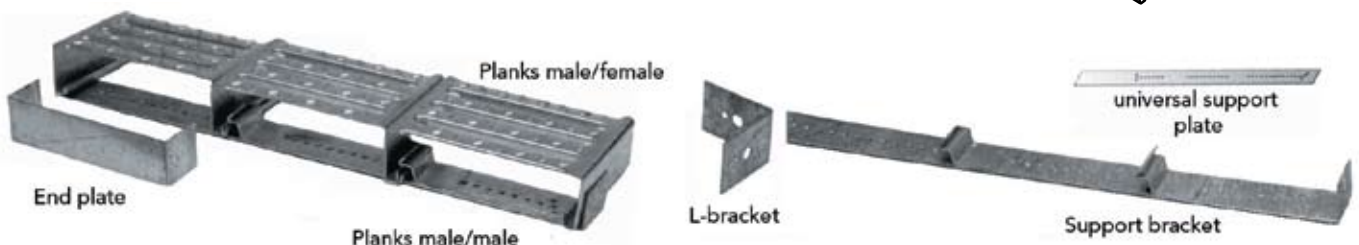

Figure 7
Cross intersection



Components

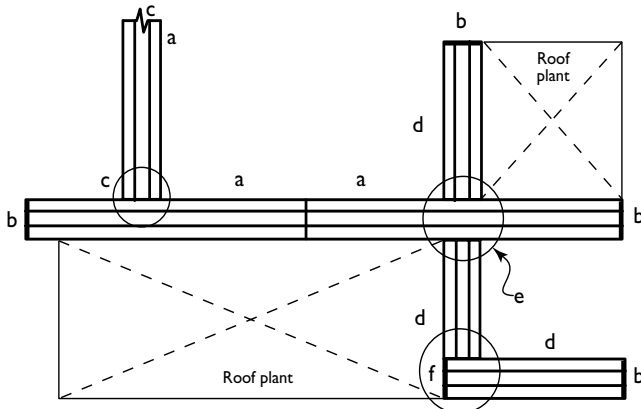

Figure 7
Kit ordering example

KITS REQUIRED FOR THIS EXAMPLE

Item	Description	Kit	No. of kits
a	Planks (675 x 6 metres)	RTK675I6073	3
b	End plates	RTK675SFEP	2
c	T-connection	RTK675TC	1
d	Planks (675 x 3 metres)	RTK675I3018	3
e	X-connection	RTK675XC	1
f	L-connection	RTK675LC	1

All ROOFTRAK systems are made up of straight lengths, connections, end plates and brackets selected from the kits and parts listed below. The example above is a 675 system. It could be made as a 450 system if required. Universal support plates may be required for some roof cladding profiles.

Components supplied in kits

Kit code	Kit Description	M/F planks	M/M planks	Support brackets	Screws (bag)	Rivets (bag)	L bracket	End plates
RTK675I6073	ROOFTRAK 675 6 metre straight run	2	1	5	1	1		
RTK675I3018	ROOFTRAK 675 3 metre straight run	2	1	3	1	1		
RTK675LC	ROOFTRAK 675 L-connection				1		1	3
RTK675TC	ROOFTRAK 675 T-connection				1		2	3
RTK675XC	ROOFTRAK 675 X-connection				1		4	
RTK675SFEP	ROOFTRAK 675 Start/finish end plate							6
RT675SB	ROOFTRAK 675 675 support bracket			1				
RTK450I6073	ROOFTRAK 450 6 metre straight run	1	1	5	1	1		
RTK450I3018	ROOFTRAK 450 3 metre straight run	1	1	3	1	1		
RTK450LC	ROOFTRAK 450 L-connection				1		1	2
RTK450TC	ROOFTRAK 450 T-connection				1		2	2
RTK450XC	ROOFTRAK 450 X-connection				1		4	
RTK450SFEP	ROOFTRAK 450 Start/finish end plate							4
RT450SB	ROOFTRAK 450 Support bracket			1				
RTHTPEPB	L-bracket						1	
RTBP	End plate							1
RTUSP	Universal Support Plate			1				

Disclaimer, warranties and limitation of liability

This publication is intended to be an aid for all trades and professionals involved with specifying and installing Lysaght products and not to be a substitute for professional judgement. Terms and conditions of sale available at local BlueScope Lysaght sales offices.

Except to the extent to which liability may not lawfully be excluded or limited, BlueScope Steel Limited will not be under or incur any liability to you for any direct or indirect loss or damage (including, without limitation, consequential loss or damage such as loss of profit or anticipated profit, loss of use, damage to goodwill and loss due to delay) however caused (including, without limitation, breach of contract, negligence and/or breach of statute), which you may suffer or incur in connection with this publication.

© Copyright BlueScope Steel Limited
June 5, 2008

6 metre planks are 6073 mm long. 3 metres planks are 3018 mm long.
Bags of screws and rivets contain 20 items.
The availability of packers or profiled spacers is subject to enquiry.

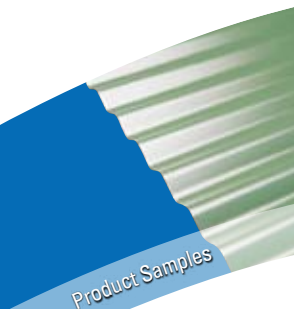

Information, brochures and your local distributor **1800 641 417**

Please check the latest information which is always available at www.lysaght.com

LYSAGHT, ROOFTRAK, KLIP-LOK and ZINCFORM are registered trademarks of BlueScope Steel Limited, ABN 16 000 011 058. Bulb-tite is a trademark of ITW Buildex. The LYSAGHT® range of products is exclusively made by BlueScope Steel Limited trading as BlueScope Lysaght. BMP 2M06/08



9 320075 052218